



ICC-ES Evaluation Report

ESR-3702

Reissued July 2023

Revised October 2023

This report is subject to renewal July 2025.

DIVISION: 09 00 00—FINISHES
Section: 09 96 43—Fire-Retardant Coatings

REPORT HOLDER:

INTERNATIONAL FIREPROOF TECHNOLOGY INC.

EVALUATION SUBJECT:

DC315 INTUMESCENT COATING

1.0 EVALUATION SCOPE

Compliance with the following codes:

- 2021, 2018, 2015, 2012, 2009 and 2006 *International Building Code*® (IBC)
- 2021, 2018, 2015, 2012, 2009 and 2006 *International Residential Code*® (IRC)

Properties evaluated:

- Application without a prescriptive thermal barrier
- Application without a prescriptive ignition barrier
- Physical properties
- Surface burning characteristics
- Water vapor transmission
- Exterior walls in Types I through IV construction

2.0 USES

DC315 is a liquid-applied coating intended for application over the surface of spray-applied foam plastic insulation complying with ICC-ES Acceptance Criteria for Spray-applied Foam Plastic Insulation (AC377). The coated assembly may be left exposed to the interior of the building without the application of a code-prescribed thermal barrier when installed as described in Section 4.2 of this report. The DC315 coating may be used in attic and crawl spaces as described in Section 4.3 of this report. See Section 4.4 for use in exterior walls of Type I, II, III and IV construction.

3.0 DESCRIPTION

3.1 General:

DC315 is a single-component, water-based, liquid-applied intumescent coating and are available in white, ice gray, dark gray and charcoal black. The coating is supplied in

5-gallon (19 L) pails and 55-gallon (208 L) drums and has a shelf life of one (1) year when stored in factory-sealed containers at temperatures between 50° and 80°F (10 and 27°C).

DC315 Primer is a liquid-applied primer, manufactured by International Fireproof Technology, Inc., and is supplied in 1- and 5-gallon (3.8 and 18.9 L) pails, and has a shelf life of 2 years when stored in factory-sealed containers at temperatures between 50° and 80°F (10 and 27°C).

DTM Bonding Primer is a waterborne, acrylic emulsion, bonding primer manufactured by Sherwin-Williams. The primer is supplied in 1- and 5-gallon (3.8 and 18.9 L) containers, and has a shelf life of three (3) years when stored in factory-sealed containers at temperatures between 50° and 100°F (10 and 38°C).

3.2 Vapor Retarder:

When a minimum thickness of 18 mils WFT [0.018 inch (0.46 mm)] of DC315 is applied to a minimum thickness of 2 inches (50.8 mm) of open-cell spray-applied foam plastic insulation, the assembly has a vapor permeance greater than 1 perm (5.7 x 10⁻¹¹ kg/Pa-s-m²) and less than 10 perms (5.7x10⁻¹⁰ kg/Pa-s-m²) when tested in accordance with ASTM E96 procedure A (desiccant method), and qualifies as a Class III vapor retarder.

3.3 Surface Burning Characteristics:

When tested in accordance with ASTM E84/UL 723, at a thickness of 13 mils WFT [0.013 inch (0.33 mm)], DC315 has a flame spread index of 25 or less and a smoke-developed index of 450 or less. The DC315 coated foam assemblies listed in Table 1 were tested in accordance with NFPA 286 and comply with the acceptance criteria of 2021 and 2018 IBC Section 803.1.1.1 (2015, 2012 and 2009 IBC Section 803.1.2.1 and 2006 IBC Section 803.2.1) and 2021, 2018, 2015, 2012 and 2009 IRC R302.9.4 (2006 IRC Section R315.4) and is permitted to be used where a Class A classification in accordance with ASTM E 84 or UL 723 is required by 2021 and 2018 IBC Section 803.13 (2015 IBC Section 803.11, 2012 and 2009 IBC Section 803.9 and 2006 IBC Section 803.5).

4.0 DESIGN AND INSTALLATION

4.1 Installation – General:

DC315 must be applied in accordance with the manufacturer's published application instructions and this

report. A copy of the instructions must be available on the job site at all times.

DC315 must be mechanically mixed prior to application. The coating is applied to the required thickness using spray equipment, a brush or a roller having a medium nap. Surfaces to be coated must be inspected in accordance with the manufacturer's published installation instructions and must be dry, clean, and free of dirt, loose debris and other substances that could interfere with the adhesion of the coating. The coating must not be applied when the ambient or surface temperature is below 50°F (10°C) or above 90°F (32° C) and relative humidity of more than 85%. The manufacturer must be consulted for specific application conditions.

4.2 Application without a Prescriptive Thermal Barrier:

The DC315 coating may be applied over spray-applied foam plastic insulations listed in Table 1 without covering the coated assembly with the thermal barrier prescribed in IBC Section 2603.4 and IRC Section R316.4 (2006 IRC Section R314.4).

The DTM Bonding Primer, when used as part of the assemblies listed in Table 1, must be installed in accordance with the manufacturer's published installation instructions.

4.3 Application without a Prescriptive Ignition Barrier:

4.3.1 General: Where spray-applied foam plastic insulations listed in Table 2 are installed in attics and crawl spaces without the ignition barrier prescribed in IBC Section 2603.4.1.6 and 2021, 2018, 2015, 2012 and 2009 IRC Sections R316.5.3 and R316.5.4 (2006 IRC Sections R314.5.3 and R314.5.4) the installation must be in accordance with Sections 4.3.2 and 4.3.3, and the following conditions apply:

- a. Entry to the attic or crawl space is only to service utilities, and no storage is permitted.
- b. There are no interconnected attic or crawl space areas.
- c. Air in the attic or crawl space is not circulated to other parts of the building.
- d. Attic ventilation is provided when required by 2021 and 2018 IBC Section 1202.2 (2015, 2012, 2009 and 2006 IBC Section 1203.2) or IRC Section R806, except when air-impermeable insulation is permitted in unvented attics in accordance with the 2021 and 2018 IBC Section 1202.3 (2015 IBC Section 1203.3) or 2021, 2018, 2015 and 2012 IRC Section R806.5 (2009 IRC Section R806.4).
- e. Under-floor (crawl space) ventilation is provided when required by 2021 and 2018 IBC Section 1202.4 [2015 IBC Section 1203.4 (2012, 2009 and 2006 IBC Section 1203.3) or IRC Section R408.1, as applicable.
- f. Combustion air is provided in accordance with IMC (*International Mechanical Code*[®]) Section 701.

4.3.2 In attics and crawl spaces: In attics, the insulation may be spray-applied to the underside of roof sheathing or roof rafters, and/or vertical surfaces; and in crawl spaces, the insulation may be spray-applied to the underside of floors and/or vertical surfaces provided the assembly conforms to one of the assemblies described in Table 2.

4.3.3 Use on Attic Floors: The insulation may be installed between and over the joists in attic floor at the maximum thickness set forth in Table 2. The insulation must be separated from the interior of the building by an approved

thermal barrier. An ignition barrier prescribed in IBC Section 2603.4.1.6 and 2018, 2015, 2012 and 2009 IRC Sections R316.5.3 and R316.5.4 (2006 IRC Sections R314.5.3 and R314.5.4) may be omitted.

4.4 Exterior Walls in Types I, II, III and IV Construction: Carlisle Spray Foam Insulation SealTite™ Pro Closed-Cell spray foam insulation may be installed in or on exterior walls of buildings of Type I, II, III and IV construction complying with IBC Section 2603.5 and as described in this section. The maximum thickness of the foam plastic installed on the exterior of the sheathing or installed in stud cavities must be as described in Table 3. The potential heat of Carlisle Spray Foam Insulation SealTite™ Pro Closed Cell spray-applied insulation is 1838 Btu/ft² (20.9 MJ/m²) per inch of thickness. The wall assembly must be as described in Table 3.

5.0 CONDITIONS OF USE

The DC315 coating described in this report complies with, or is a suitable alternative to what is specified in, those codes listed in Section 1.0 of this report, subject to the following conditions:

- 5.1** Application must comply with this report, the manufacturer's published installation instructions, and the applicable code. A copy of the installation instructions must be on the job site during application of the coating. In the event of a conflict between the manufacturer's published installation instructions and this report, this report and the code govern.
- 5.2** The application of additional interior finishes over the DC315 coating is limited to interior/exterior satin latex paint applied at an average wet film thickness of 8.0 mils (0.20 mm) or interior/exterior coating consisting of 30% silicon alkyd having a VOC (less exempt solvents) of no more than 340 g/L (2.8 lb/gal) and a volume solids content of 62% applied at a maximum average wet film thickness of 8 mils (0.20 mm). The use of either of the two interior finishes in conjunction with a vapor retardant coating is outside the scope of this report.
- 5.3** Installation in accordance with this report is for the specific assemblies and spray-applied foam plastic insulations described in Tables 1 and 2. The spray-applied foam plastic insulation must be installed in accordance with the requirements set forth in the specific ICC-ES evaluation report noted. For spray-applied foam plastic insulation that is not covered in an ICC-ES evaluation report, the evaluation is limited as noted in Tables 1 and 2, Footnote 3.
- 5.4** When used in or on the exterior walls of buildings of Type I, II III or IV construction, the wall assembly must conform to those described in Section 4.7, Table 3 and Figures 1 - 4.
- 5.5** The coating is manufactured in Taoyuan, Taiwan and Irvine, California, under a quality control program with inspections by ICC-ES.

6.0 EVIDENCE SUBMITTED

- 6.1** Data in accordance with the ICC-ES Acceptance Criteria for Fire-Protective Coatings Applied to Spray-applied Foam Plastic Insulation Installed without a Code-prescribed Thermal Barrier (AC456), dated October 2015 (Editorially revised February 2022), including room corner fire testing in accordance with NFPA 286.
- 6.2** Report of testing in accordance with ASTM E84 (UL 723).

- 6.3 Report of vapor permeance test in accordance with ASTM E96 (Desiccant method).
- 6.4 Report of testing in accordance with Appendix X of AC377.
- 6.5 Report of fire propagation characteristics testing in accordance with NFPA 285 and associated fire engineering analysis supporting the NFPA 285 test report.
- 6.6 Data on accelerated weathering, resistance to humidity and thermal cycling testing in accordance with ASTM D5894, ASTM D4585 and ASTM D3346, respectively.

7.0 IDENTIFICATION

- 7.1 All containers of DC315 coating must be labeled with the manufacturer’s name (International Fireproof

Technology Inc.) and address; the product name; the date of manufacture, the shelf life or expiration date; the manufacturer’s instructions for application, and the evaluation report number (ESR-3702).

The spray-applied foam plastic insulations must be labeled in accordance with the applicable evaluation report (see Table 1).

- 7.2 The report holder’s contact information is the following:

INTERNATIONAL FIREPROOF TECHNOLOGY INC.
17528 VON KARMAN AVENUE
IRVINE, CALIFORNIA 92614
(949) 975-8588
www.painttoprotect.com
ptp@painttoprotect.com

**TABLE 1—USE OF INSULATION WITHOUT A PRESCRIPTIVE THERMAL BARRIER
 (TESTED IN ACCORDANCE WITH NFPA 286)**

INSULATION COMPANY NAME	INSULATION PRODUCT NAME	MAXIMUM THICKNESS (in.) (Vertical Surfaces)	MAXIMUM THICKNESS (in.) (Overhead Surfaces)	DC315 COATING MINIMUM AVERAGE THICKNESS ¹ (Applied to all Foam Surfaces)	MINIMUM THEORETICAL APPLICATION RATE OF COATING ²
Acme Urethanes	WC-50 (See Note 3)	8	14	12 mils DFT 18 mils WFT	1.13 gal/100 ft ²
AMBIT Polyurethane LLC	AMBI-SEAL 5.0 (See Note 3)	8	14	12 mils DFT 18 mils WFT	1.13 gal/100 ft ²
AMBIT Polyurethane LLC	AmbiTite 204 (HFO) (ESR-4427)	8	12	9 mils DFT 14 mils WFT	0.88 gal/100 ft ²
AMBIT Polyurethane LLC	AmbiTite 201 245fa (ESR-4426)	8	12	9 mils DFT 14 mils WFT	0.88 gal/100 ft ²
AMD Distribution LLC	Diamond Back (ESR-4438)	7½	11½	9 mils DFT 14 mils WFT	0.88 gal/100 ft ²
Barnhardt Manufacturing Company dba NCFI Polyurethanes	InsulStar® Light 12-008 (See Note 3)	8	14	9 mils DFT 14 mils WFT	0.88 gal/100 ft ²
Barnhardt Manufacturing Company dba NCFI Polyurethanes	InsulBloc® (ESR-1615)	5½	9½	9 mils DFT 14 mils WFT	0.88 gal/100 ft ²
Barnhardt Manufacturing Company dba NCFI Polyurethanes	InsulStar® (ESR-1615)	5½	9½	9 mils DFT 14 mils WFT	0.88 gal/100 ft ²
Barnhardt Manufacturing Company dba NCFI Polyurethanes	InsulStar® 1.7 SmartSPF™ (See Note 3)	5½	9½	9 mils DFT 14 mils WFT	0.88 gal/100 ft ²
Barnhardt Manufacturing Company dba NCFI Polyurethanes	InsulBloc® 1.7 SmartSPF™ (See Note 3)	5½	9½	9 mils DFT 14 mils WFT	0.88 gal/100 ft ²
Barnhardt Manufacturing Company dba NCFI Polyurethanes	Sealtite OCX (See Note 3)	10	14	12 mils DFT 18 mils WFT	1.13 gal/100 ft ²
Barnhardt Manufacturing Company dba NCFI Polyurethanes	InsulStar®SmartSPF™ (See Note 3)	6	10	9 mils DFT 14 mils WFT	0.88 gal/100 ft ²
Barnhardt Manufacturing Company dba NCFI Polyurethanes	InsulBloc®SmartSPF™ (See Note 3)	6	10	9 mils DFT 14 mils WFT	0.88 gal/100 ft ²
Barnhardt Manufacturing Company dba NCFI Polyurethanes	NCFI 23-026 (See Note 3)	6	6	12 mils DFT 18 mils WFT	1.13 gal/100 ft ²
BASF Corporation	ENERTITE® G (ESR-3102)	8½	14	9 mils DFT 14 mils WFT	0.88 gal/100 ft ²
BASF Corporation	ENERTITE® IB-418 (ESR-3102)	8½	14	9 mils DFT 14 mils WFT	0.88 gal/100 ft ²
BASF Corporation	ENERTITE® NM (ESR-3102)	8½	14	9 mils DFT 14 mils WFT	0.88 gal/100 ft ²
BASF Corporation	SPRAYTITE 158 (ESR-5215)	5½	9½	9 mils DFT 14 mils WFT	0.88 gal/100 ft ²
BASF Corporation	SPRAYTITE 178 (ESR-5215)	5½	11½	14 mils DFT 20 mils WFT	1.25 gal/100 ft ²

INSULATION COMPANY NAME	INSULATION PRODUCT NAME	MAXIMUM THICKNESS (in.) (Vertical Surfaces)	MAXIMUM THICKNESS (in.) (Overhead Surfaces)	DC315 COATING MINIMUM AVERAGE THICKNESS ¹ (Applied to all Foam Surfaces)	MINIMUM THEORETICAL APPLICATION RATE OF COATING ²
BASF Corporation	SPRAYTITE 81205 (See Note 3)	5½	9½	9 mils DFT 14 mils WFT	0.88 gal/100 ft ²
BASF Corporation	SPRAYTITE 81206 (ESR-5215)	5½	11½	14 mils DFT 20 mils WFT	1.25 gal/100 ft ²
BASF Corporation	SPRAYTITE SP (ESR-5215)	5½	9½	9 mils DFT 14 mils WFT	0.88 gal/100 ft ²
BASF Corporation	WALLTITE 200 (See Note 3)	5½	11½	14 mils DFT 20 mils WFT	1.25 gal/100 ft ²
BASF Corporation	WALLTITE HP+ (See Note 3)	5½	11½	14 mils DFT 20 mils WFT	1.25 gal/100 ft ²
BASF Corporation	WALLTITE US (ESR-5215)	5½	11½	14 mils DFT 20 mils WFT	1.25 gal/100 ft ²
BASF Corporation	WALLTITE US-N (See Note 3)	5½	11½	14 mils DFT 20 mils WFT	1.25 gal/100 ft ²
BASF Corporation	SPRAYTITE LWP-L (See Note 3)	5½	9½	9 mils DFT 14 mils WFT	0.88 gal/100 ft ²
BASF Corporation	WALLTITE LWP (ESR-2642)	5½	11½	14 mils DFT 20 mils WFT	1.25 gal/100 ft ²
BASF Corporation	WALLTITE HP+S (See Note 3)	5½	11½	14 mils DFT 20 mils WFT	1.25 gal/100 ft ²
BASF Corporation	Spraytite Comfort (ESR-5215)	5½	9½	9 mils DFT 14 mils WFT	0.88 gal/100 ft ²
BASF Corporation	Spraytite Comfort Plus (See Note 3)	5½	9½	9 mils DFT 14 mils WFT	0.88 gal/100 ft ²
Carlisle Spray Foam Insulation	Foamsulate 50 (See Note 3)	8½	14	9 mils DFT 14 mils WFT	0.88 gal/100 ft ²
Carlisle Spray Foam Insulation	Foamsulate 50 HY (See Note 3)	8½	14	9 mils DFT 14 mils WFT	0.88 gal/100 ft ²
Carlisle Spray Foam Insulation	Foamsulate 70 (See Note 3)	8½	14	9 mils DFT 14 mils WFT	0.88 gal/100 ft ²
Carlisle Spray Foam Insulation	Foamsulate Closed Cell (See Note 3)	5½	9½	9 mils DFT 14 mils WFT	0.88 gal/100 ft ²
Carlisle Spray Foam Insulation	Foamsulate HFO (See Note 3)	5½	9½	9 mils DFT 14 mils WFT	0.88 gal/100 ft ²
Carlisle Spray Foam Insulation	Foamsulate OCX (See Note 3)	9	14	9 mils DFT 14 mils WFT	0.88 gal/100 ft ²
Carlisle Spray Foam Insulation	SealTite PRO Closed Cell (See Note 3)	5½	9½	9 mils DFT 14 mils WFT	0.88 gal/100 ft ²
Carlisle Spray Foam Insulation	SealTite PRO High Yield (See Note 3)	8½	14	9 mils DFT 14 mils WFT	0.88 gal/100 ft ²
Carlisle Spray Foam Insulation	SealTite PRO No Mix (See Note 3)	8½	14	9 mils DFT 14 mils WFT	0.88 gal/100 ft ²
Carlisle Spray Foam Insulation	SealTite PRO No Trim 21 (See Note 3)	8½	14	9 mils DFT 14 mils WFT	0.88 gal/100 ft ²
Carlisle Spray Foam Insulation	SealTite PRO OCX (See Note 3)	9	14	9 mils DFT 14 mils WFT	0.88 gal/100 ft ²
Carlisle Spray Foam Insulation	SealTite PRO One Zero Closed Cell (See Note 3)	5½	9½	9 mils DFT 14 mils WFT	0.88 gal/100 ft ²
Carlisle Spray Foam Insulation	SealTite PRO Open Cell (See Note 3)	8½	14	9 mils DFT 14 mils WFT	0.88 gal/100 ft ²
Carlisle Spray Foam Insulation	SealTite™ PRO HFO (See Note 3)	7½	11½	9 mils DFT 14 mils WFT	0.88 gal/100 ft ²
Commercial Thermal Solutions, Inc.	Tiger Foam® E-84 Fire-Rated SPF Class 1 Spray Foam System (ESR-3183)	3½	3½	13 mils DFT 20 mils WFT	1.25 gal/100 ft ²
Creative Polymer Solutions	Accufoam CC (See Note 3)	5½	9½	13 mils DFT 19 mils WFT	1.19 gal/100 ft ²
Creative Polymer Solutions	Accufoam OC (See Note 3)	8	14	12 mils DFT 18 mils WFT	1.13 gal/100 ft ²
Creative Polymer Solutions	Accufoam 2.0 Regular HFO (See Note 3)	7½	9½	9 mils DFT 14 mils WFT	0.88 gal/100 ft ²
Creative Polymer Solutions	AccuFoam AF1 (See Note 3)	8	14	12 mils DFT 18 mils WFT	1.13 gal/100 ft ²
Creative Polymer Solutions	AirLok 45 (See Note 3)	8	14	12 mils DFT 18 mils WFT	1.13 gal/100 ft ²

INSULATION COMPANY NAME	INSULATION PRODUCT NAME	MAXIMUM THICKNESS (in.) (Vertical Surfaces)	MAXIMUM THICKNESS (in.) (Overhead Surfaces)	DC315 COATING MINIMUM AVERAGE THICKNESS ¹ (Applied to all Foam Surfaces)	MINIMUM THEORETICAL APPLICATION RATE OF COATING ²
DAP Foam, Inc.	Touch N' Foam Professional Class I FR Spray Foam System (ESR-3052)	3 1/2	3 1/2	13 mils DFT 20 mils WFT	1.25 gal/100 ft ²
DAP Foam, Inc.	Touch N' Seal Class I FR Spray Foam System (ESR-3052)	3 1/2	3 1/2	13 mils DFT 20 mils WFT	1.25 gal/100 ft ²
DAP Foam, Inc.	TNF/TNS Class I FR HFO Spray Foam System (See Note 3)	3 1/4	3 1/4	12 mils DFT 18 mils WFT	1.13 gal/100 ft ²
DuPont de Nemours, Inc.	FROTH-PAK™ (ESR-3228)	3 1/2	3 1/2	14 mils DFT 20 mils WFT	1.25 gal/100 ft ²
Elastochem Specialty Chemicals, Inc.	Elastochem® Insulthane® Extreme (See Note 3)	7 1/4	7 1/4	12 mils DFT 18 mils WFT	1.13 gal/100 ft ²
Elastochem Specialty Chemicals, Inc.	Insulthane 200 Evolution (See Note 3)	5 1/2	9 1/2	9 mils DFT 14 mils WFT	0.88 gal/100 ft ²
Elastochem Specialty Chemicals, Inc.	Insulthane® 450 NM (See Note 3)	10	14	8 mils DFT 14 mils WFT	0.88 gal/100 ft ²
Elastochem Specialty Chemicals, Inc.	Elastochem 500 (See Note 3)	8	12	13.7 mils DFT 20.5 mils WFT	1.28 gal /100 ft ²
EnergyOne America	EOA 2000 (See Note 3)	5 1/2	9 1/2	9 mils DFT 14 mils WFT	0.88 gal/100 ft ²
EnergyOne America	EOA 500 (ESR-3686)	8 1/2	14	9 mils DFT 14 mils WFT	0.88 gal/100 ft ²
Foam Suppliers	EcoStar CC (See Note 3)	8	12	12 mils DFT 18 mils WFT	1.13 gal/100 ft ²
Foam Suppliers	Genfoam OC (See Note 3)	8 1/2	14	12 mils DFT 18 mils WFT	1.13 gal/100 ft ²
Foam Suppliers	GenX (See Note 3)	7 1/2	11 1/2	13 mils DFT 20 mils WFT	1.25 gal/100 ft ²
Franklin International, Inc.	Titebond Weathermaster Superfoam (ESR-4099)	2	2	13 mils DFT 20 mils WFT	1.25 gal/100 ft ²
Gaco Western	F1850 (See Note 3)	5 1/2	9 1/2	9 mils DFT 14 mils WFT	0.88 gal/100 ft ²
Gaco Western	Gaco 183M (See Note 3)	5 1/2	9 1/2	9 mils DFT 14 mils WFT	0.88 gal/100 ft ²
Gaco Western	GACO F1880 (See Note 3)	9	12	9 mils DFT 14 mils WFT	0.88 gal/100 ft ²
Gaco Western	Gaco Firestop2 F5001 (See Note 3)	18	18	12 mils DFT 18 mils WFT	1.13 gal/100 ft ²
Gaco Western	Gaco Green 052N (See Note 3)	11 1/4	11 1/4	9 mils DFT 14 mils WFT	0.88 gal/100 ft ²
Gaco Western	GacoEZSpray F4500 (See Note 3)	8 1/2	14	9 mils DFT 14 mils WFT	0.88 gal/100 ft ²
General Coatings Manufacturing Corp.	Ultrathane 050 (See Note 3)	8	10	13 mils DFT 20 mils WFT	1.25 gal/100 ft ²
General Coatings Manufacturing Corp.	Ultra-Thane 230 (See Note 3)	5 1/2	7 1/2	DTM Bonding Primer 3 mils DFT/ 4 mils WFT & DC315 12 mils DFT/ 18 mils WFT	0.25 gal/100 ft ² & 1.13 gal/100 ft ²
General Coatings Manufacturing Corp.	Ultrathane 202 (See Note 3)	8	12	12 mils DFT 18 mils WFT	1.13 gal/100 ft ²
General Coatings Manufacturing Corp.	UPC 2.0 (See Note 3)	8	12	12 mils DFT 18 mils WFT	1.13 gal/100 ft ²
General Coatings Manufacturing Corp.	Ultrathane 050 Max (See Note 3)	8	14	14 mils DFT 21 mils WFT	1.31 gal/100 ft ²
General Coatings Manufacturing Corp.	Ultrathane 170 (See Note 3)	8	12	11 mils DFT 16 mils WFT	1.00 gal/100 ft ²
General Coatings Manufacturing Corp.	Ultrathane 205 HFO (See Note 3)	8	12	11 mils DFT 16 mils WFT	1.00 gal/100 ft ²
General Coatings Manufacturing Corp.	Ultrathane 202 MAX (See Note 3)	8	12	11 mils DFT 16 mils WFT	1.00 gal/100 ft ²
General Coatings Manufacturing Corp.	UPC 2.0 MAX (ESR-3805)	8	12	11 mils DFT 16 mils WFT	1.00 gal/100 ft ²
Genyk	Elite 2.0 (ESR-5150)	5 1/2	9 1/2	15 mils DFT 23 mils WFT	1.44 gal/100 ft ²

INSULATION COMPANY NAME	INSULATION PRODUCT NAME	MAXIMUM THICKNESS (in.) (Vertical Surfaces)	MAXIMUM THICKNESS (in.) (Overhead Surfaces)	DC315 COATING MINIMUM AVERAGE THICKNESS ¹ (Applied to all Foam Surfaces)	MINIMUM THEORETICAL APPLICATION RATE OF COATING ²
Guardian Energy Technologies	Foam It Green (See Note 3)	3½	3½	13 mils DFT 20mils WFT	1.25 gal/100 ft ²
Henry Company	Permax 1.8 (See Note 3)	11¼	11¼	14 mils DFT 21 mils WFT	1.31 gal/100 ft ²
Henry Company	Permax 2.0X (See Note 3)	5½	9½	9 mils DFT 14 mils WFT	0.88 gal/100 ft ²
Henry Company	Permax 2.0X Fast (See Note 3)	5½	9½	9 mils DFT 14 mils WFT	0.88 gal/100 ft ²
Huntsman Building Solutions	Agribalance® (ESR-2600)	7½	11½	12 mils DFT 18 mils WFT	1.13 gal/100 ft ²
Huntsman Building Solutions	APX® 2.0 (See Note 3)	5¼	14	13 mils DFT 20 mils WFT	1.25 gal/100 ft ²
Huntsman Building Solutions	APX™ (See Note 3)	8	10	13 mils DFT 20 mils WFT	1.25 gal/100 ft ²
Huntsman Building Solutions	Heatlok® HFO (ESR-4073)	7½	11½	9 mils DFT 14 mils WFT	0.88 gal/100 ft ²
Huntsman Building Solutions	Heatlok® XT-s (ESR-3824)	7½	11½	9 mils DFT 14 mils WFT	0.88 gal/100 ft ²
Huntsman Building Solutions	Heatlok® XT-w (ESR-3883)	7½	11½	12 mils DFT 18 mils WFT	1.13 gal/100 ft ²
Huntsman Building Solutions	Demilec SEALECTION® 500 (ESR-1172)	7½	11½	12 mils DFT 18 mils WFT	1.13 gal/100 ft ²
Huntsman Building Solutions	HEATLOK SOY® 200 PLUS (See Note 3)	7½	11½	12 mils DFT 18 mils WFT	1.13 gal/100 ft ²
Huntsman Building Solutions	Heatlok® Eco (ESR-3198)	5½	9½	14 mils DFT 22 mils WFT	1.38 gal/100 ft ²
Huntsman Building Solutions	Heatlok HFO Pro (See Note 3)	8	11½	12 mils DFT 18 mils WFT	1.13 gal/100 ft ²
Huntsman Building Solutions	Sealection® NM (ESR-2668)	7½	11½	12 mils DFT 18 mils WFT	1.13 gal/100 ft ²
Huntsman Building Solutions	LD C 50 No Mix (See Note 3)	8½	14	9 mils DFT 14 mils WFT	0.88 gal/100 ft ²
Huntsman Building Solutions	Classic (ESR-1826)	8½	14	9 mils DFT 14 mils WFT	0.88 gal/100 ft ²
Huntsman Building Solutions	Classic Plus (ESR-1826)	8½	14	9 mils DFT 14 mils WFT	0.88 gal/100 ft ²
Huntsman Building Solutions	Classic Ultra (ESR-1826)	8½	14	9 mils DFT 14 mils WFT	0.88 gal/100 ft ²
Huntsman Building Solutions	Classic Ultra Select (ESR-1826)	8½	14	9 mils DFT 14 mils WFT	0.88 gal/100 ft ²
Huntsman Building Solutions	MD-C-200 (ESR-3199)	6	10	14 mils DFT 22 mils WFT	1.38 gal/100 ft ²
Huntsman Building Solutions	ProSeal HFO (See Note 3)	5½	9½	9 mils DFT 14 mils WFT	0.88 gal/100 ft ²
Huntsman Building Solutions	ProSeal Max HFC (See Note 3)	6	9½	9 mils DFT 14 mils WFT	0.88 gal/100 ft ²
Huntsman Building Solutions	Foam-Lok FL 450 (ESR-4242)	8½	14	9 mils DFT 14 mils WFT	0.88 gal/100 ft ²
Huntsman Building Solutions	Prime Gold (See Note 3)	8½	14	9 mils DFT 14 mils WFT	0.88 gal/100 ft ²
Huntsman Building Solutions	Foam-Lok FL2000 (ESR-2629)	5½	9½	9 mils DFT 14 mils WFT	0.88 gal/100 ft ²
Huntsman Building Solutions	Foam-Lok FL500 (ESR-2847)	8½	14	9 mils DFT 14 mils WFT	0.88 gal/100 ft ²
Huntsman Building Solutions	Lapolla FL 2000 4G (See Note 3)	5½	9½	9 mils DFT 14 mils WFT	0.88 gal/100 ft ²
Huntsman Building Solutions	Foam-Lok FL 750 (ESR-4322)	8½	14	9 mils DFT 14 mils WFT	0.88 gal/100 ft ²
Huntsman Building Solutions	Foam-Lok FL2000-3G (ESR-4501)	5½	9½	9 mils DFT 14 mils WFT	0.88 gal/100 ft ²
Huntsman Building Solutions	ProSeal (ESR-3500)	5½	9½	9 mils DFT 14 mils WFT	0.88 gal/100 ft ²
Huntsman Building Solutions	ProSeal LE (ESR-3500)	5½	9½	9 mils DFT 14 mils WFT	0.88 gal/100 ft ²
ICP Construction Inc. dba ICP Building Solutions Group	HandiFoam E-84 Class 1(A) Spray Foam System (ESR-2717)	3½	3½	13 mils DFT 20mils WFT	1.25 gal/100 ft ²
ICP Construction Inc. dba ICP Building Solutions Group	HandiFoam E84 HFO (ESR-2717)	4	4	12 mils DFT 18 mils WFT	1.13 gal/100 ft ²

INSULATION COMPANY NAME	INSULATION PRODUCT NAME	MAXIMUM THICKNESS (in.) (Vertical Surfaces)	MAXIMUM THICKNESS (in.) (Overhead Surfaces)	DC315 COATING MINIMUM AVERAGE THICKNESS ¹ (Applied to all Foam Surfaces)	MINIMUM THEORETICAL APPLICATION RATE OF COATING ²
ICP Construction Inc., dba ICP Building Solutions Group	HandiFoam HVLP MD 2.0 (ESR-4287)	5 ¹ / ₂	11 ¹ / ₂	DC315 Prime Coat 3mils DFT / 4 mils WFT & DC315 11 mils DFT / 16 mils WFT	0.25 gal/100 ft ² & 1.00 gal/100 ft ²
ICP Construction Inc., dba ICP Building Solutions Group	HandiFoam HVPL HFO 2.0 (ESR-4287)	5 ¹ / ₂	7 ¹ / ₂	13 mils DFT 20 mils WFT	1.25 gal/100 ft ²
Johns Manville	JM Corbond III (See Note 3)	5 ¹ / ₂	9 ¹ / ₂	9 mils DFT 14 mils WFT	0.88 gal/100 ft ²
Johns Manville	JM Corbond MCS™ (See Note 3)	7 ¹ / ₄	9 ¹ / ₄	14 mils DFT 22 mils WFT	1.38 gal/100 ft ²
Johns Manville	JM Corbond oc (See Note 3)	7 ¹ / ₂	11 ¹ / ₂	12 mils DFT 18 mils WFT	1.13 gal/100 ft ²
Johns Manville	JM Corbond ocx SPF (See Note 3)	9	14	9 mils DFT 14 mils WFT	0.88 gal/100 ft ²
Johns Manville	JM MCS+ (See Note 3)	5 ¹ / ₂	9 ¹ / ₂	9 mils DFT 14 mils WFT	0.88 gal/100 ft ²
Johns Manville	JM Gen IV (See Note 3)	5 ¹ / ₂	9 ¹ / ₂	9 mils DFT 14 mils WFT	0.88 gal/100 ft ²
Natural Polymers, LLC	Natural-Therm™ 0.5 IB (See Note 3)	9 ¹ / ₂	14 ¹ / ₂	9 mils DFT 14 mils WFT	0.88 gal/100 ft ²
Natural Polymers, LLC	Natural-Therm™ 0.50 PCF (See Note 3)	9 ¹ / ₂	14 ¹ / ₂	9 mils DFT 14 mils WFT	0.88 gal/100 ft ²
Natural Polymers, LLC	Natural-Therm™ 2.0 IBS (See Note 3)	5 ¹ / ₂	9 ¹ / ₂	9 mils DFT 14 mils WFT	0.88 gal/100 ft ²
Natural Polymers, LLC	Natural-Therm™ 2.0 IBW (See Note 3)	5 ¹ / ₂	9 ¹ / ₂	9 mils DFT 14 mils WFT	0.88 gal/100 ft ²
Natural Polymers, LLC	Natural-Therm™ Light (See Note 3)	9 ¹ / ₂	14 ¹ / ₂	9 mils DFT 14 mils WFT	0.88 gal/100 ft ²
Natural Polymers, LLC	Natural-Therm™ ZERO (See Note 3)	5 ¹ / ₂	9 ¹ / ₂	9 mils DFT 14 mils WFT	0.88 gal/100 ft ²
Natural Polymers, LLC	Natural-Therm® 2.0 HFO IBW IBS (See Note 3)	7 ¹ / ₂	11 ¹ / ₂	12 mils DFT 18 mils WFT	1.13 gal/100 ft ²
Natural Polymers, LLC	Ultra Pure LD (See Note 3)	9 ¹ / ₂	14 ¹ / ₂	9 mils DFT 14 mils WFT	0.88 gal/100 ft ²
Natural Polymers, LLC	Ultra Pure HD (See Note 3)	7 ¹ / ₂	11 ¹ / ₂	12 mils DFT 18 mils WFT	1.13 gal/100 ft ²
North American Spray Foam Polymers	EcoPolySeal (ESR-4483)	7 ¹ / ₂	11 ¹ / ₂	12 mils DFT 18 mils WFT	1.13 gal/100 ft ²
North American Spray Foam Polymers	EPS 2000 (ESR-4484)	7 ¹ / ₂	11 ¹ / ₂	12 mils DFT 18 mils WFT	1.13 gal/100 ft ²
Nu-Wool Company Incorporated	Nu-Seal 0.5 (See Note 3)	9 ¹ / ₂	14 ¹ / ₂	9 mils DFT 14 mils WFT	0.88 gal/100 ft ²
Nu-Wool Company Incorporated	Nu-Seal 2.0 HFO (See Note 3)	8	12	11 mils DFT 16 mils WFT	1.00 gal/100 ft ²
Nu-Wool Company Incorporated	Nu-Seal 2.0 (See Note 3)	5 ¹ / ₂	14	9 mils DFT 14 mils WFT	0.88 gal/100 ft ²
PCC Prodex Sp. z.o.o.	Crossin 450 (See Note 3)	8	14	12 mils DFT 18 mils WFT	1.13 gal/100 ft ²
Polygreen Solutions	GreenSeal 44 (See Note 3)	8	14	12 mils DFT 18 mils WFT	1.13 gal/100 ft ²
Preferred Solutions, Inc.	Staycell® 302 (See Note 3)	5 ¹ / ₂	9 ¹ / ₂	9 mils DFT 14 mils WFT	0.88 gal/100 ft ²
ProFoam Corporation	ProSeal™ (ESR-3835)	5 ¹ / ₂	9 ¹ / ₂	9 mils DFT 14 mils WFT	0.88 gal/100 ft ²
ProFoam Corporation	ProSeal Plus (See Note 3)	5 ¹ / ₂	9 ¹ / ₂	9 mils DFT 14 mils WFT	0.88 gal/100 ft ²
ProFoam Corporation	ProFill Plus (See Note 3)	8 ¹ / ₂	14	9 mils DFT 14 mils WFT	0.88 gal/100 ft ²
Purinova Sp. z.o.o.	Purinova PURIOS 500 (ESR-4165)	8	14	12 mils DFT 18 mils WFT	1.13 gal/100 ft ²
Quadrant Urethane Technologies	EnviroSeal OCX (See Note 3)	8 ¹ / ₂	13 ¹ / ₂	12 mils DFT 18 mils WFT	1.13 gal/100 ft ²
Quadrant Urethane Technologies	EnviroSeal HY (High Yield) (See Note 3)	8	12	13 mils DFT 20 mils WFT	1.25 gal/100 ft ²
Quadrant Urethane Technologies	EnviroSeal No Mix (See Note 3)	8	12	13 mils DFT 20 mils WFT	1.25 gal/100 ft ²
Quadrant Urethane Technologies	EnviroSeal HFO (See Note 3)	5 ¹ / ₂	9 ¹ / ₂	9 mils DFT 14 mils WFT	0.88 gal/100 ft ²

INSULATION COMPANY NAME	INSULATION PRODUCT NAME	MAXIMUM THICKNESS (in.) (Vertical Surfaces)	MAXIMUM THICKNESS (in.) (Overhead Surfaces)	DC315 COATING MINIMUM AVERAGE THICKNESS ¹ (Applied to all Foam Surfaces)	MINIMUM THEORETICAL APPLICATION RATE OF COATING ²
RHH Foam Systems	Versi-Foam Class I (See Note 3)	3½	3½	13 mils DFT 20 mils WFT	1.25 gal/100 ft ²
Rhino Linings Corporation	ThermalGuard CC2 (ESR-2100)	5½	9½	9 mils DFT 14 mils WFT	0.88 gal/100 ft ²
Rhino Linings Corporation	ThermalGuard OC.5 (ESR-2100)	7½	11½	13 mils DFT 18 mils WFT	1.13 gal/100 ft ²
SES Foam	Nexseal 2.0 (See Note 3)	5½	9½	9 mils DFT 14 mils WFT	0.88 gal/100 ft ²
SES Foam	Nexseal 2.0 LE (See Note 3)	5½	9½	9 mils DFT 14 mils WFT	0.88 gal/100 ft ²
SES Foam	SES 2.0 (See Note 3)	5½	9½	9 mils DFT 14 mils WFT	0.88 gal/100 ft ²
SES Foam	SES 2.0 LE (See Note 3)	5½	9½	9 mils DFT 14 mils WFT	0.88 gal/100 ft ²
SES Foam	SES Foam Easyseal 0.5 lb (See Note 3)	8½	14	9 mils DFT 14 mils WFT	0.88 gal/100 ft ²
SES Foam	Sucraseal™ 0.5 (ESR-3375)	9	14	9 mils DFT 14 mils WFT	0.88 gal/100 ft ²
SFM Foam	OC NM Pro (See Note 3)	10	14	8 mils DFT 14 mils WFT	0.88 gal/100 ft ²
SFM Foam	OC Pro (See Note 3)	8	12	13.7 mils DFT 20.5 mils WFT	1.28 gal /100 ft ²
SFM Foam	CC Pro (See Note 3)	5½	9½	9 mils DFT 14 mils WFT	0.88 gal/100 ft ²
SFM Foam	CC HFO Pro (See Note 3)	7¼	7¼	12 mils DFT 18 mils WFT	1.13 gal/100 ft ²
Soprema	SupraSeal (See Note 3)	7¼	7¼	12 mils DFT 18 mils WFT	1.13 gal/100 ft ²
Specialty Products, Inc. (S.P.I)	Envelo-Seal™ 0.5 OC (See Note 3)	9½	14½	9 mils DFT 14 mils WFT	0.88 gal/100 ft ²
Specialty Products, Inc. (S.P.I)	Envelo-Seal™ 2.0 IBW (See Note 3)	5½	14	9 mils DFT 14 mils WFT	0.88 gal/100 ft ²
Spray Foam Polymers LLC	ThermoSeal 500 HY (See Note 3)	8	12	13.7 mils DFT 20.5 mils WFT	1.28 gal /100 ft ²
Spray Foam Polymers LLC	Thermoseal OCX (See Note 3)	7½	11½	12 mils DFT 18 mils WFT	1.13 gal/100 ft ²
Spray Foam Polymers LLC	2000 (See Note 3)	5½	9½	9 mils DFT 14 mils WFT	0.88 gal/100 ft ²
Spray Foam Polymers LLC	Thermoseal CCX (ESR-4137)	7½	11½	9 mils DFT 14 mils WFT	0.88 gal/100 ft ²
Spray Foam Polymers LLC	TS 5G (See Note 3)	5½	9½	9 mils DFT 14 mils WFT	0.88 gal/100 ft ²
Spray Foam Polymers LLC	TS One (See Note 3)	5½	9½	13 mils DFT 20 mils WFT	1.25 gal/100 ft ²
Spray Foam Polymers LLC	TS360 (See Note 3)	8½	14	13 mils DFT 20 mils WFT	1.25 gal/100 ft ²
Spray Foam Polymers LLC	TS500 (See Note 3)	8	14	12 mils DFT 18 mils WFT	1.13 gal/100 ft ²
Spray Foam Polymers LLC	TS800 (See Note 3)	8	14	12 mils DFT 18 mils WFT	1.13 gal/100 ft ²
Sustainable Polymer Products	0.5 OC (See Note 3)	8½	14	9 mils DFT 14 mils WFT	0.88 gal/100 ft ²
Sustainable Polymer Products	0.5 OCX (See Note 3)	9	14	9 mils DFT 14 mils WFT	0.88 gal/100 ft ²
Sustainable Polymer Products	2.0 CC (See Note 3)	5½	9½	9 mils DFT 14 mils WFT	0.88 gal/100 ft ²
SWD Urethane	Quik-Shield 100X (See Note 3)	7	11	12 mils DFT 18 mils WFT	1.13 gal/100 ft ²
SWD Urethane	Quik-Shield 104 (See Note 3)	8	14	12 mils DFT 18 mils WFT	1.13 gal/100 ft ²
SWD Urethane	Quik-Shield 106 (See Note 3)	11¼	11¼	15 mils DFT 24 mils WFT	1.50 gal/100 ft ²
SWD Urethane	Quik-Shield 108 (See Note 3)	8½	14	9 mils DFT 14 mils WFT	0.88 gal/100 ft ²
SWD Urethane	Quik-Shield 112 (See Note 3)	5½	9½	9 mils DFT 14 mils WFT	0.88 gal/100 ft ²
SWD Urethane	Quik-Shield 118 (See Note 3)	5½	9½	9 mils DFT 14 mils WFT	0.88 gal/100 ft ²
SWD Urethane	Quik-Shield 144 (See Note 3)	5½	9½	9 mils DFT 14 mils WFT	0.88 gal/100 ft ²

INSULATION COMPANY NAME	INSULATION PRODUCT NAME	MAXIMUM THICKNESS (in.) (Vertical Surfaces)	MAXIMUM THICKNESS (in.) (Overhead Surfaces)	DC315 COATING MINIMUM AVERAGE THICKNESS ¹ (Applied to all Foam Surfaces)	MINIMUM THEORETICAL APPLICATION RATE OF COATING ²
The Spray Market	SPM-200 (See Note 3)	7½	11½	9 mils DFT 14 mils WFT	0.88 gal/100 ft ²
Universal Polymers Corporation	UPC 500 (ESR-3803)	8½	14	12 mils DFT 18 mils WFT	1.13 gal/100 ft ²
Universal Polymers Corporation	UPC 500 OCX (See Note 3)	7½	11½	13 mils DFT 20 mils WFT	1.25 gal/100 ft ²
Universal Polymers Corporation	UPC 2.0 High Lift (See Note 3)	8	12	11 mils DFT 16 mils WFT	1.00 gal/100 ft ²
Universal Polymers Corporation	UPC 1.7 (See Note 3)	8	12	11 mils DFT 16 mils WFT	1.00 gal/100 ft ²
Universal Polymers Corporation	UPC 2.0 (See Note 3)	8	12	12 mils DFT 18 mils WFT	1.13 gal/100 ft ²
Universal Polymers Corporation	UPC 500 Max (See Note 3)	8	14	14 mils DFT 21 mils WFT	1.31 gal/100 ft ²
Universal Polymers Corporation	UPC 2.0 HFO (See Note 3)	8	12	11 mils DFT 16 mils WFT	1.00 gal/100 ft ²
Urethane Technology Company, Inc.	UTC 7040-0.5 (ESR-3244)	5½	14¾	14 mils DFT 20 mils WFT	1.25 gal/100 ft ²
Urethane Technology Company, Inc.	UTC 7041-0.5 (ESR-3244)	5½	14¾	14 mils DFT 20 mils WFT	1.25 gal/100 ft ²
Victory Polymers Corp.	VPC-HFO (See Note 3)	7¼	7¼	12 mils DFT 18 mils WFT	1.13 gal/100 ft ²
Victory Polymers Corp.	VPC-50 OCHY (See Note 3)	8½	11½	9 mils DFT 14 mils WFT	0.88 gal/100 ft ²
Victory Polymers Inc.	VPC-CC SuperLift and VPC-CC SuperYield (ESR-4334)	7½	11½	12 mils DFT 18 mils WFT	1.13 gal/100 ft ²
Victory Polymers Inc.	VPC-OneStroke (See Note 3)	7½	11½	12 mils DFT 18 mils WFT	1.13 gal/100 ft ²
Victory Polymers Inc.	VPC-HiR-OC (See Note 3)	8½	11½	9 mils DFT 14 mils WFT	0.88 gal/100 ft ²
Victory Polymers Inc.	VPC-50NF (ESR-4657)	7½	11½	12 mils DFT 18 mils WFT	1.13 gal/100 ft ²
Victory Polymers Inc.	VPC 50 OC (See Note 3)	10	14	8 mils DFT 14 mils WFT	0.88 gal/100 ft ²
Victory Polymers Inc.	VPC 200 OC (See Note 3)	5½	9½	9 mils DFT 14 mils WFT	0.88 gal/100 ft ²
Victory Polymers Inc.	VPC HFO High Lift (See Note 3)	7¼	7¼	12 mils DFT 18 mils WFT	1.13 gal/100 ft ²
Volatile Free, Inc.	VFI-714 (See Note 3)	5½	9½	9 mils DFT 14 mils WFT	0.88 gal/100 ft ²
Volatile Free, Inc.	VFI-716 (See Note 3)	8½	14	9 mils DFT 14 mils WFT	0.88 gal/100 ft ²
Xcelus	XLS-2000 (See Note 3)	7¼	7¼	12 mils DFT 18 mils WFT	1.13 gal/100 ft ²
Xcelus	XLS-200 (See Note 3)	5½	9½	9 mils DFT 14 mils WFT	0.88 gal/100 ft ²
Xcelus	XLS 500 (See Note 3)	8	12	13.7 mils DFT 20.5 mils WFT	1.28 gal /100 ft ²
Xcelus	XLS 200 (See Note 3)	5½	9½	9 mils DFT 14 mils WFT	0.88 gal/100 ft ²
Xcelus	XLS 2000 (See Note 3)	7¼	7¼	12 mils DFT 18 mils WFT	1.13 gal/100 ft ²
XtremeSeal, LLC	XtremeSeal 0.4 LX (See Note 3)	8½	14	9 mils DFT 14 mils WFT	0.88 gal/100 ft ²
XtremeSeal, LLC	XtremeSeal 0.5 LX (See Note 3)	8½	14	9 mils DFT 14 mils WFT	0.88 gal/100 ft ²
XtremeSeal, LLC	XtremeSeal 2.0 LE (See Note 3)	5½	9½	9 mils DFT 14 mils WFT	0.88 gal/100 ft ²

For SI: 1 inch = 25.4 mm; 1 mil = 0.0254 mm; 1 gallon = 3.38 L; 1 ft² = 0.93 m².

Notes:

¹DFT = Dry Film Thickness; WFT = Wet Film Thickness

²As reported in the manufacturer's application instructions. Actual application rate, based upon specific project conditions, must be in accordance with the manufacturer's application instructions.

³Evaluation is limited to the NFPA 286 test data for the coated assembly described. Evaluation for compliance of the spray foam insulation with other applicable requirements of AC377 and the IBC and IRC are outside the scope of the report.

**TABLE 2—USE OF INSULATION WITHOUT A PRESCRIPTIVE IGNITION BARRIER
(TESTED IN ACCORDANCE WITH APPENDIX X OF AC377)**

INSULATION COMPANY NAME	INSULATION PRODUCT NAME	MAXIMUM THICKNESS (in.) (Vertical Surfaces and Attic Floors)	MAXIMUM THICKNESS (in.) (Underside of Roof Sheathing and/or Rafters, Underside of Floors)	DC315 COATING MINIMUM AVERAGE THICKNESS ¹ (Applied to all Foam Surfaces)	MINIMUM THEORETICAL APPLICATION RATE OF COATING ²
Acme Urethanes	WC-50 (See Note 3)	8	14	3 mils DFT 4 mils WFT	0.25 gal/100 ft ²
Barnhardt Manufacturing Company dba NCFI Polyurethanes	InsulStar® Light (12-008) (See Note 3)	8	14	4 mils DFT 7 mils WFT	0.44 gal/100 ft ²
BASF Corporation	ENERTITE® G (ESR-3102)	11½	15½	3 mils DFT 4 mils WFT	0.25 gal/100 ft ²
BASF Corporation	ENERTITE® NM (ESR-3102)	11½	15½	3 mils DFT 4 mils WFT	0.25 gal/100 ft ²
BASF Corporation	SPRAYTITE 158 (ESR-5215)	5½	11½	3 mils DFT 4 mils WFT	0.25 gal/100 ft ²
BASF Corporation	SPRAYTITE 178 (ESR-5215)	5½	11½	3 mils DFT 4 mils WFT	0.25 gal/100 ft ²
BASF Corporation	SPRAYTITE 81205 (See Note 3)	5½	11½	3 mils DFT 4 mils WFT	0.25 gal/100 ft ²
BASF Corporation	SPRAYTITE 81206 (ESR-5215)	5½	11½	3 mils DFT 4 mils WFT	0.25 gal/100 ft ²
BASF Corporation	SPRAYTITE SP (ESR-5215)	5½	11½	3 mils DFT 4 mils WFT	0.25 gal/100 ft ²
BASF Corporation	WALLTITE HP+ (See Note 3)	5½	11½	3 mils DFT 4 mils WFT	0.25 gal/100 ft ²
BASF Corporation	WALLTITE US (ESR-5215)	5½	11½	3 mils DFT 4 mils WFT	0.25 gal/100 ft ²
BASF Corporation	WALLTITE US-N (See Note 3)	5½	11½	3 mils DFT 4 mils WFT	0.25 gal/100 ft ²
Carlisle Spray Foam Insulation	Foamsulate 50 (See Note 3)	12	12	3 mils DFT 4 mils WFT	0.25 gal/100 ft ²
Carlisle Spray Foam Insulation	Foamsulate 70 (See Note 3)	14	14	3 mils DFT 4 mils WFT	0.25 gal/100 ft ²
Carlisle Spray Foam Insulation	SealTite PRO No Mix (See Note 3)	12	12	3 mils DFT 4 mils WFT	0.25 gal/100 ft ²
Carlisle Spray Foam Insulation	SealTite PRO No Trim 21 (See Note 3)	14	14	3 mils DFT 4 mils WFT	0.25 gal/100 ft ²
Creative Polymer Solutions	Accufoam CC (See Note 3)	5½	9½	3 mils DFT 4 mils WFT	0.25 gal/100 ft ²
Creative Polymer Solutions	Accufoam OC (See Note 3)	8	14	3 mils DFT 4 mils WFT	0.25 gal/100 ft ²
Creative Polymer Solutions	Accufoam AF1 (See Note 3)	8	14	3 mils DFT 4 mils WFT	0.25 gal/100 ft ²
Creative Polymer Solutions	AirLok 45 (See Note 3)	8	14	3 mils DFT 4 mils WFT	0.25 gal/100 ft ²
DAP Foam, Inc.	TNF Class I FR HFO Spray Foam System (See Note 3)	3¼	3¼	4 mils DFT 6 mils WFT	0.38 gal/100 ft ²
Elastochem Specialty Chemicals, Inc	Elastochem 500 (See Note 3)	7¾	11½	3 mils DFT 4 mils WFT	0.25 gal/100 ft ²
Elastochem Specialty Chemicals, Inc	Insulthane 450NM (See Note 3)	7¾	11½	3 mils DFT 4 mils WFT	0.25 gal/100 ft ²
Gaco Western	Gaco Green 052N (See Note 3)	11¼	11¼	3 mils DFT 4 mils WFT	0.25 gal/100 ft ²
Foam Suppliers	EcoStar CC (See Note 3)	7½	11½	3 mils DFT 4 mils WFT	0.25 gal/100 ft ²
Foam Suppliers	Genfoam OC (See Note 3)	8½	14	4 mils DFT 6 mils WFT	0.38 gal/100 ft ²
Gaco Western	GacoEZSpray F4500 (See Note 3)	12	16	3 mils DFT 4 mils WFT	0.25 gal/100 ft ²
General Coatings Manufacturing Corp.	Ultrathane 050 (See Note 3)	6	8	3 mils DFT 4 mils WFT	0.25 gal/100 ft ²
General Coatings Manufacturing Corp.	Ultra-Thane 230 (See Note 3)	7½	11½	3 mils DFT 4 mils WFT	0.25 gal/100 ft ²
General Coatings Manufacturing Corp.	Ultra-Thane 202 (See Note 3)	7½	11½	3 mils DFT 4 mils WFT	0.25 gal/100 ft ²
General Coatings Manufacturing Corp.	Ultra-Thane 205 HFO/UPC 2.0 HFO (See Note 3)	8	12	4 mils DFT 6 mils WFT	0.38 gal/100 ft ²
General Coatings Manufacturing Corp.	Ultra-Thane 205 HFO High Lift / UPC 2.0 HFO	8	12	4 mils DFT 6 mils WFT	0.38 gal/100 ft ²

INSULATION COMPANY NAME	INSULATION PRODUCT NAME	MAXIMUM THICKNESS (in.) (Vertical Surfaces and Attic Floors)	MAXIMUM THICKNESS (in.) (Underside of Roof Sheathing and/or Rafters, Underside of Floors)	DC315 COATING MINIMUM AVERAGE THICKNESS ¹ (Applied to all Foam Surfaces)	MINIMUM THEORETICAL APPLICATION RATE OF COATING ²
	High Lift (See Note 3)				
Huntsman Building Solutions	Sealection® NM (ESR-2668)	10	12	4 mils DFT 6 mils WFT	0.38 gal/100 ft ²
Huntsman Building Solutions	Classic (ESR-1826)	5½	14	3 mils DFT 4 mils WFT	0.25 gal/100 ft ²
Huntsman Building Solutions	Classic Plus (ESR-1826)	8	14	3 mils DFT 4 mils WFT	0.25 gal/100 ft ²
Huntsman Building Solutions	Classic Ultra (ESR-1826)	5½	14	3 mils DFT 4 mils WFT	0.25 gal/100 ft ²
Huntsman Building Solutions	Classic Ultra Select (ESR-1826)	5½	14	3 mils DFT 4 mils WFT	0.25 gal/100 ft ²
Huntsman Building Solutions	MD-C-200 (ESR-3199)	8	14	3 mils DFT 4 mils WFT	0.25 gal/100 ft ²
Huntsman Building Solutions	Agribalance® (ESR-2600)	7½	11½	3 mils DFT 4 mils WFT	0.25 gal/100 ft ²
Huntsman Building Solutions	SEALECTION® 500 (ESR-1172)	7½	11½	3 mils DFT 4 mils WFT	0.25 gal/100 ft ²
Huntsman Building Solutions	Heatlok® Eco (ESR-3198)	11½	11½	3 mils DFT 4 mils WFT	0.25 gal/100 ft ²
Huntsman Building Solutions	Foam-Lok FL 450 (ESR-4242)	5½	14	3 mils DFT 4 mils WFT	0.25 gal/100 ft ²
Huntsman Building Solutions	Prime Gold (See Note 3)	5½	14	3 mils DFT 4 mils WFT	0.25 gal/100 ft ²
Huntsman Building Solutions	Foam-Lok FL500 (ESR-2847)	5½	11½	3 mils DFT 4 mils WFT	0.25 gal/100 ft ²
Huntsman Building Solutions	ProSeal (ESR-3500)	8	14	3 mils DFT 4 mils WFT	0.25 gal/100 ft ²
Huntsman Building Solutions	ProSeal LE (ESR-3500)	8	14	3 mils DFT 4 mils WFT	0.25 gal/100 ft ²
ICP Construction Inc., dba ICP Building Solutions Group	HandiFoam HVLP MD 2.0 (ESR-4287)	5½	11½	3 mils DFT 4 mils WFT	0.25 gal/100 ft ²
ICP Construction Inc., dba ICP Building Solutions Group	HandiFoam HVLP HFO 2.0 (ESR-4287)	5½	11½	3 mils DFT 4 mils WFT	0.25 gal/100 ft ²
Johns Manville	JM Corbond III (See Note 3)	7½	9½	3 mils DFT 4 mils WFT	0.25 gal/100 ft ²
Johns Manville	JM MCS+ (See Note 3)	7½	9½	3 mils DFT 4 mils WFT	0.25 gal/100 ft ²
Natural Polymers, LLC	Natural-Therm™ HFO (See Note 3)	7½	11½	3 mils DFT 4 mils WFT	0.25 gal/100 ft ²
Natural Polymers, LLC	Natural-Therm™ ZERO (See Note 3)	7½	11½	3 mils DFT 4 mils WFT	0.25 gal/100 ft ²
PCC Prodex S.P z.o.o.	Crossin 450 (See Note 3)	8	14	3 mils DFT 4 mils WFT	0.25 gal/100 ft ²
Polygreen Solutions	GreenSeal 44 (See Note 3)	8	14	3 mils DFT 4 mils WFT	0.25 gal/100 ft ²
Profoam	ProFill Plus (See Note 3)	8	14	3 mils DFT 4 mils WFT	0.25 gal/100 ft ²
Purinova Sp. Z.o.o.	Purinova PURIOS 500 (ESR-4165)	8	14	3 mils DFT 4 mils WFT	0.25 gal/100 ft ²
Rhino Linings Corporation	ThermalGuard OC .5 (ESR-2100)	8	12	3 mils DFT 4 mils WFT	0.25 gal/100 ft ²
Rhino Linings Corporation	ThermalGuard 1.0 (See Note 3)	8	12	3 mils DFT 4 mils WFT	0.25 gal/100 ft ²
SES Foam	SES Foam 0.5 lb (See Note 3)	9½	11½	3 mils DFT 4 mils WFT	0.25 gal/100 ft ²
SFM Foam	OC NM Pro (See Note 3)	7¾	11½	3 mils DFT 4 mils WFT	0.25 gal/100 ft ²
SFM Foam	OC Pro (See Note 3)	7¾	11½	3 mils DFT 4 mils WFT	0.25 gal/100 ft ²
Spray Foam Polymers LLC	ThermoSeal 500 HY	7¾	11½	3 mils DFT 4 mils WFT	0.25 gal/100 ft ²
Spray Foam Polymers LLC	TS 360 (See Note 3)	8½	14	4 mils DFT 6 mils WFT	0.25 gal/100 ft ²
Spray Foam Polymers LLC	TS 600 (See Note 3)	9½	14	4 mils DFT 6 mils WFT	0.25 gal/100 ft ²
Spray Foam Polymers LLC	TS 800 (See Note 3)	9½	14	4 mils DFT 6 mils WFT	0.38 gal/100 ft ²

INSULATION COMPANY NAME	INSULATION PRODUCT NAME	MAXIMUM THICKNESS (in.) (Vertical Surfaces and Attic Floors)	MAXIMUM THICKNESS (in.) (Underside of Roof Sheathing and/or Rafters, Underside of Floors)	DC315 COATING MINIMUM AVERAGE THICKNESS ¹ (Applied to all Foam Surfaces)	MINIMUM THEORETICAL APPLICATION RATE OF COATING ²
Sustainable Polymer Products	0.5 OC HY (See Note 3)	9 ¹ / ₂	11 ¹ / ₂	3 mils DFT 4 mils WFT	0.25 gal/100 ft ²
SWD Urethane	Quik-Shield 108 (See Note 3)	8	12	3 mils DFT 4 mils WFT	0.25 gal/100 ft ²
Universal Polymers Corporation	UPC 500 (ESR-3803)	8 ¹ / ₂	14	4 mils DFT 6 mils WFT	0.38 gal/100 ft ²
Universal Polymers Corporation	UPC 2.0 High Lift (See Note 3)	8	12	4 mils DFT 6 mils WFT	0.38 gal/100 ft ²
Universal Polymers Corporation	UPC 2.0 (See Note 3)	7 ¹ / ₂	11 ¹ / ₂	3 mils DFT 4 mils WFT	0.25 gal/100 ft ²
Urethane Technology Company, Inc.	UTC 7040-0.5 (ESR-3244)	5 ¹ / ₂	14 ³ / ₄	3 mils DFT 4 mils WFT	0.25 gal/100 ft ²
Urethane Technology Company, Inc.	UTC 7041-0.5 (ESR-3244)	5 ¹ / ₂	14 ³ / ₄	3 mils DFT 4 mils WFT	0.25 gal/100 ft ²
Victory Polymers Corp.	VPC-50 OCHY (See Note 3)	12	12	3 mils DFT 4 mils WFT	0.25 gal/100 ft ²
Victory Polymers Inc.	VPC-OneStroke (See Note 3)	7 ¹ / ₂	11 ¹ / ₂	12 mils DFT 18 mils WFT	1.13 gal/100 ft ²
Victory Polymers Inc.	VPC-HiR-OC (See Note 3)	14	14	3 mils DFT 4 mils WFT	0.25 gal/100 ft ²
Victory Polymers Inc.	VPC-50NF (ESR-4657)	10	12	4 mils DFT 6 mils WFT	0.38 gal/100 ft ²
Victory Polymers Inc.	VPC 50 OC (See Note 3)	7 ³ / ₄	11 ¹ / ₂	3 mils DFT 4 mils WFT	0.25 gal/100 ft ²
Xcelus	XLS 500 (See Note 3)	7 ³ / ₄	11 ¹ / ₂	3 mils DFT 4 mils WFT	0.25 gal/100 ft ²
XtremeSeal, LLC	XtremeSeal 0.4 LX (See Note 3)	8	12	3 mils DFT 4 mils WFT	0.25 gal/100 ft ²
XtremeSeal, LLC	XtremeSeal 0.5 LX (See Note 3)	9 ¹ / ₂	11 ¹ / ₂	3 mils DFT 4 mils WFT	0.25 gal/100 ft ²

For SI: 1 inch = 25.4 mm; 1 mil = 0.0254 mm; 1 gallon = 3.38 L; 1 ft² = 0.93 m².

Notes:

¹DFT = Dry Film Thickness; WFT = Wet Film Thickness

²As reported in the manufacturer's application instructions. Actual application rate, based upon specific project conditions, must be in accordance with the manufacturer's application instructions.

³Evaluation is limited to the NFPA 286 test data for the coated assembly described. Evaluation for compliance of the spray foam insulation with other applicable requirements of AC377 and the IBC and IRC are outside the scope of the report.

TABLE 3—NFPA 285 COMPLYING EXTERIOR WALL ASSEMBLIES

WALL COMPONENTS	MATERIALS
Base wall system— Use either 1, 2 or 3	1 — Concrete wall 2 — Concrete masonry wall 3 — 1 layer of 5/8-inch-thick Type X gypsum wallboard on interior, installed over minimum 35/8-inch-deep, minimum No. 20-gage steel studs spaced at a maximum of 24 inches on center with lateral bracing every 4 feet as required by the code.
Floorline firestopping	4 pcf mineral-fiber insulation friction-fit in each wall stud cavity at each floor line. Thickness must match stud cavity depth.
Cavity insulation— Use either 1, 2, 3 or 4	1 — None 2 — Spray-applied foam plastic insulation, maximum 35/8-inch-thick of Carlisle SealTite™ Pro Closed Cell ⁴ applied to Base wall 3, covering the width of the stud cavity and either fully filling the stud cavity depth or partially filling the stud cavity depth leaving a maximum air space of 15/8 inches. 3 — Fiberglass batt insulation, Class A (faced or unfaced) ¹ 4 — Mineral-fiber insulation complying with ASTM E136 ¹
Exterior sheathing— Use 1 with Base Wall 1 or 2, Use 2 with Base Wall 3	1 — None 2 — Minimum 1/2-inch-thick ASTM C1177 complying exterior sheathing
Exterior Insulation	1 — Maximum 31/2-inch-thick of Carlisle SealTite™ Pro Closed Cell ⁴ spray foam insulation, applied directly to the exterior face of the exterior sheathing of Base wall 3 or directly to the exterior face of Base wall 1 or 2, 2 — The exposed surface of the spray foam insulation must be covered with International Fireproof Technology, Inc. DC315 intumescent coating applied at a minimum average 16 mils wet film thickness 3 — The DC315 coating must be covered with Sherwin-Williams SHER-CRYL HPA topcoat applied at a minimum average 12 mils wet film thickness ²
Exterior wall covering—Use either 1 through 12	1 — Brick —Standard nominally 4-inch-thick clay brick with brick veneer anchors installed a maximum of 24 inches on center vertically on each stud. Maximum 2-inch air gap between exterior insulation and brick. 2 — Cast concrete – Minimum 1-inch-thick, using any standard non-open-jointed installation. —Maximum 2-inch air gap between exterior insulation and cast concrete. 3 — Concrete masonry units – Minimum 21/2-inch-thick, using any standard non-open-jointed installation. — Maximum 2-inch air gap between exterior insulation and concrete masonry units. 4 — Natural stone veneer – Minimum 2-inch-thick, using any standard non-open-jointed installation technique 5 — Terracotta cladding – Use any terracotta cladding system in which the terracotta is minimum 11/4-inch-thick, using any standard non-open-jointed installation technique. 6 — Stucco – Minimum 3/4 –inch-thick, code-complying three-coat exterior cement plaster and lath. 7 — Aluminum cladding panels, vertical interlocking type – Minimum 0.030-inch-thick using the framing system specified in footnote 3. 8 — Corrosion-resistant steel cladding panels, interlocking type – minimum 0.0149-inch-thick using the framing system specified in footnote 3. 9 — Cold-rolled copper cladding panels, interlocking type – minimum 0.0216-inch-thick, minimum 16 ounces per square foot, using the framing system specified in footnote 3. 10 — Fiber-cement siding – Minimum 0.25 inches thick, using any standard non-open-jointed installation. 11 — One-coat Stucco – Minimum thickness as stated in a current ICC-ES evaluation report where the one-coat stucco has been qualified for compliance under AC11. 12 — Thin brick veneer – Minimum 1/4-inch thick thin brick complying with ASTM C1088, adhered to minimum 3/4 –inch-thick, code-complying three-coat exterior cement plaster and lath mortar bed.
Opening Flashing	Minimum 0.030-inch-thick aluminum flashing installed at all openings to completely cover the opening header, jambs and sill

For SI: 1 inch = 25.4 mm, 1 foot = 304.8 mm, 1 pcf = 16.01 kg/m³.

¹Insulation must comply with the applicable requirements of 2021, 2018, 2015 or 2012 IBC Section 720.2 (2009 IBC Section 719.2).

²Coating must be applied in accordance with the coating manufacturer’s published installation instructions.

³Framing for Exterior wall coverings 7, 8, and 9 consists of minimum 22 gage steel C-channel with 13/8-inch legs (54 mm) installed around the perimeter of any window opening or door opening through the exterior sheathing to the steel studs. 4-inch deep (101 mm), 20-gage steel Z-girts with 2-inch legs (51 mm) secured through exterior sheathing to studs at 24 inches (610 mm) on-center. Hat Channels [1-inch deep (25.4 mm), 37/8-inch tall (99 mm)] 22-gage steel hat channels fastened at 24 inches (610 mm) on-center to the Z-girts. Z-girts may be installed horizontally or vertically. The cladding edges interlock together such that all edges and fasteners are concealed after installation. The maximum air space between the exterior face of the spray-applied foam plastic insulation and the back of the exterior wall covering cladding panels described in 7, 8 and 9 must not exceed 21/2 inches (64 mm).

⁴Evaluation is limited to the NFPA 285 test data for the assembly described. Evaluation for compliance of the spray foam insulation with other applicable requirements of AC377 and the IBC and IRC are outside the scope of the report.

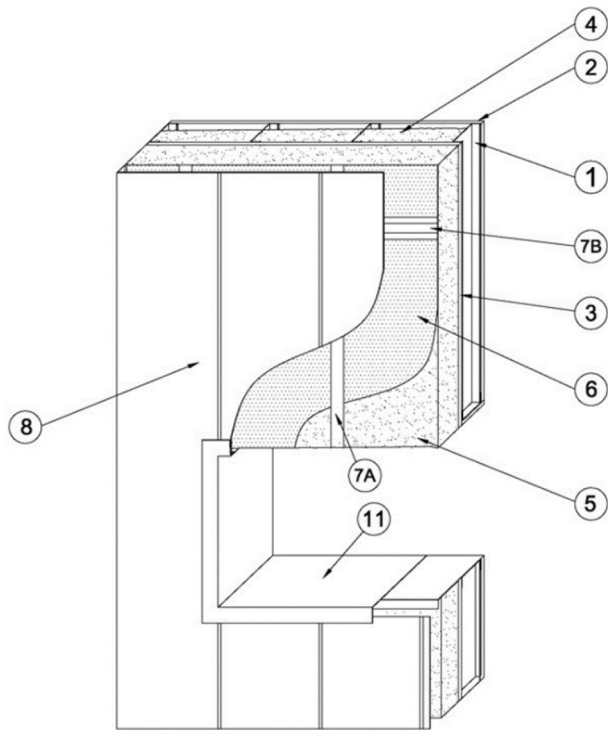

1. Steel Studs — See Table 3, Base Wall System 3 (See Alternate Base Wall in Table 3).
Systems
2. Interior Gypsum Board — See Table 3.
3. Exterior Gypsum Sheathing — See Table 3.
4. Cavity Insulation — See Table 3
5. Exterior Insulation — See Table 3.
6. Exterior Insulation Intumescent Coating — See Table 3, Items 2 and 3.
7. Mounting System — See Table 3.
- 7A. Z-Girts and Window Channel — See Table 3, Footnote 3.
- 7B. Hat Channels — See Table 3, Footnote 3.
8. Exterior Cladding — See Table 3 Claddings 7, 8 or 9. (Other Claddings in Table 3 are not shown)
10. Floorline Firestopping — See Table 3.
11. Window Flashing — See Table 3, Footnote 3.

FIGURE 1—TABLE 3 (COMPONENTS)*

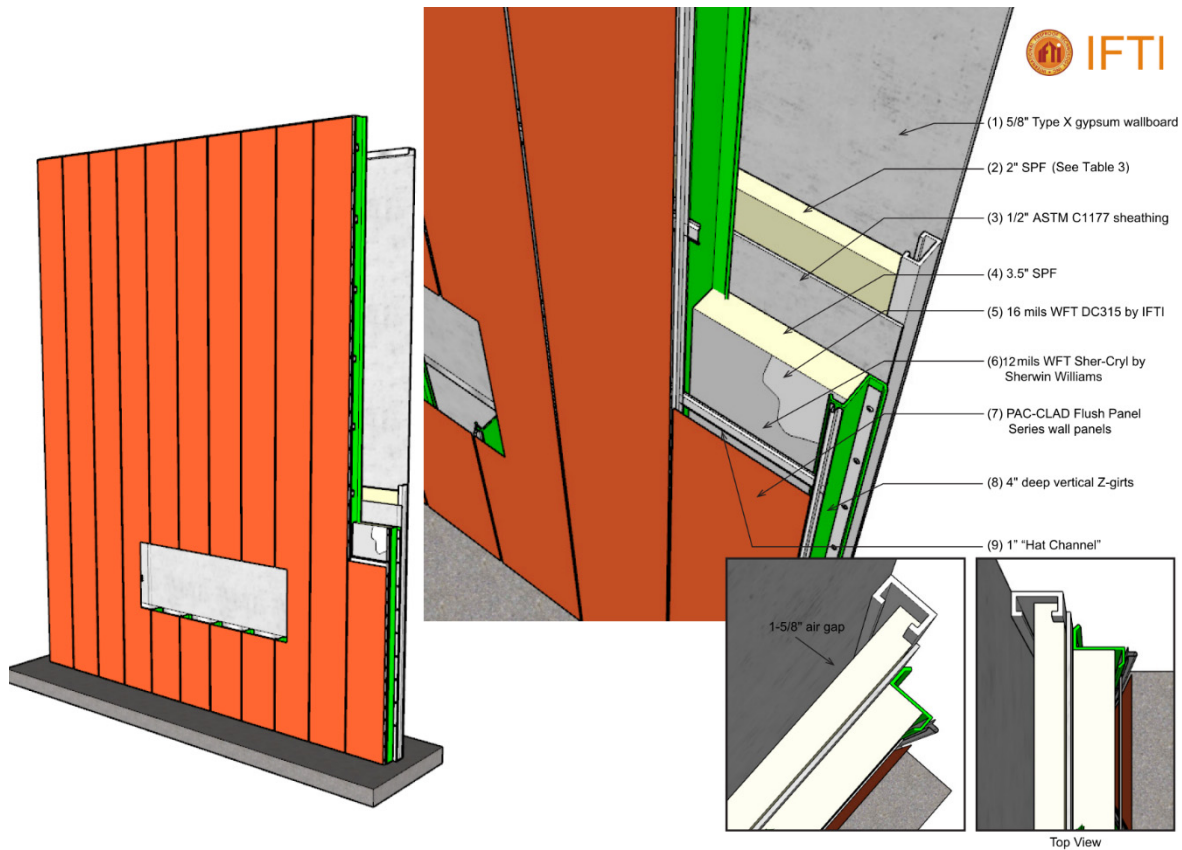

FIGURE 2—TABLE 3 (WALL DETAILS)*

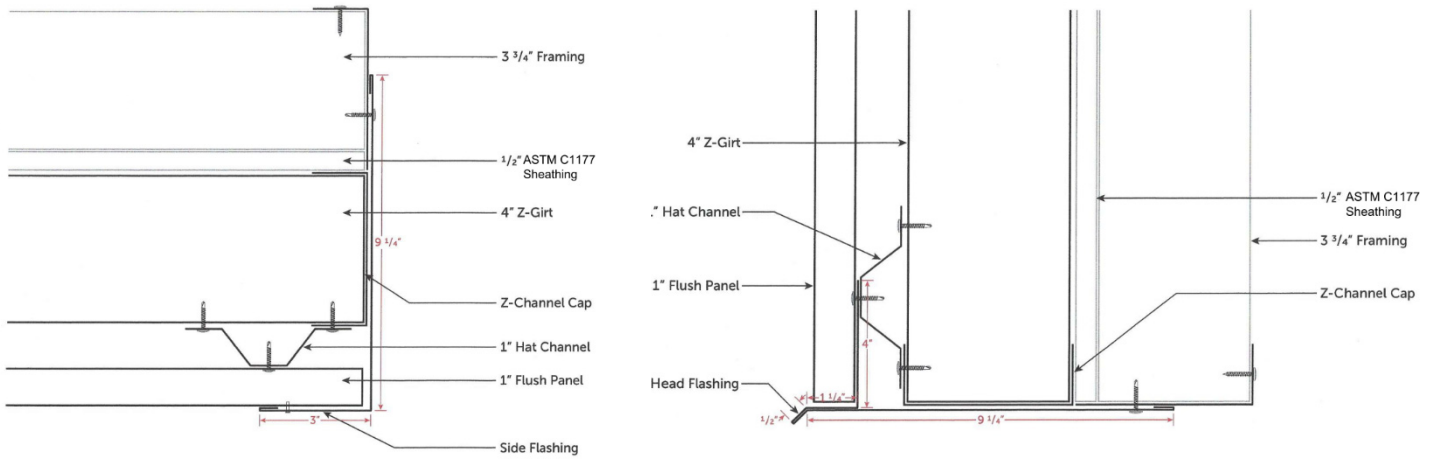

FIGURE 3—TABLE 3 (OPENING DETAILS)*

*In the event of conflict between the written descriptions in Table 3 and the Figure, the written description applies.